

## Battery Status

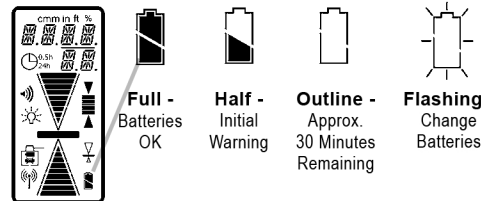

## Move clamp position

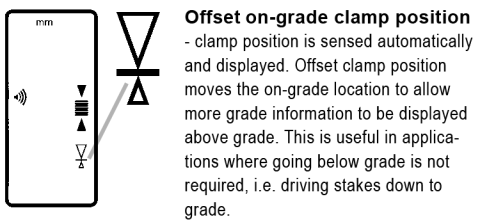

## Rod Clamp

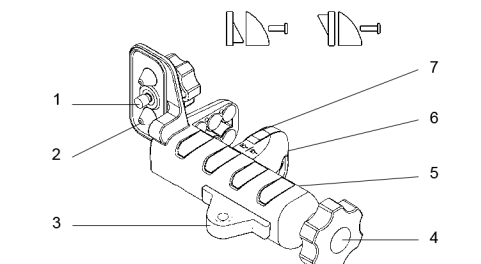

1. Captive Rod Clamp Screw - attaches to the back of detector.
2. Alignment Points (2) - help secure and align rod clamp.
3. Level Vial - can be viewed from above or below to verify that the rod is plumb.
4. Clamping Screw Knob - secures clamp to rods by moving the traveling jaw. Clockwise tightens; Counterclockwise loosens.
5. Reference Bar - top of bar is aligned with on-grade.
6. Traveling Jaw - moving jaw grips tightly to rods.
7. Reversible Face - slanted face for round and oval rods; flat face for rectangular and square rods.

## Specifications

Working Radius: (Laser dependent):	1 m - 460 m (3 ft - 1500 ft)		
Laser Detection Height:	127.0 mm	(5")	
Numeric Readout Height:	102.0 mm	(4")	
Internal Radio:	Full 2-way communication, operation and security lock with paired device Up to 220 m (720 ft), depending on orientation, conditions and paired device		
Radio Working Radius:	Up to 220 m (720 ft), depending on orientation, conditions and paired device		
Accuracy (Deadband):			
Ultra Fine	0.5 mm	0.02 in	1/32 in
Super Fine	1.0 mm	0.05 in	1/16 in
Fine	2.0 mm	0.10 in	1/8 in
Medium	5.0 mm	0.20 in	1/4 in
Coarse	10.0 mm	0.50 in	1/2 in
Calibration	0.1 mm	0.01 in	1/64 in
Reception Angle:	± 45° minimum		
Detectable Spectrum:	610 nm ... 780 nm (HL760) 520 nm ... 780 nm (HL760U)		
Beeper Volumes:	Loud = 110 dBA Medium = 95 dBA Low = 65 dBA		
LED Grade Indicators:	Front, Green on-grade, Red Hi, Blue Low		
Power Supply:	2 x 1.5 Volt "AA" batteries		
Battery Life:	60+ hours		
Automatic Shut Off:	Selectable, 30 min, 24 h, Off		
Environmental:	Waterproof, Dustproof to IP67		
Weight without clamp:	371 g (13.1 oz.)		
Dimensions without clamp:	168.0 x 76.0 x 36.0 mm (6.6" x 3.0" x 1.4")		
Operating Temperature:	-20°C...+60°C (-4°F... +140°F)		
Storage Temperature:	-40°C...+70°C (-40°F...+158°F)		

\*Specifications subject to change without notice.

## Warranty

Trimble warrants the HL760 / 760U to be free of defects in material and workmanship for a period of three years. Trimble or its authorized service center will repair or replace, at its option, any defective part, or the entire product, for which notice has been given during the warranty period. If required, travel and per diem expenses to and from the place where repairs are made will be charged to the customer at the prevailing rates. Customers should send the product to Trimble Navigation Ltd. or the nearest authorized service center for warranty repairs or exchange, freight prepaid. Any evidence of negligent, abnormal use, accident, or any attempt to repair the product by other than factory-authorized personnel using Trimble certified or recommended parts, automatically voids the warranty. The foregoing states the entire liability of Trimble regarding the purchase and use of its equipment. Trimble will not be held responsible for any consequential loss or damage of any kind. This warranty is in lieu of all other warranties, except as set forth above, including any implied warranty merchantability of fitness for a particular purpose, are hereby disclaimed. This warranty is in lieu of all other warranties, expressed or implied.



### EMC Declaration of Conformity

This device has been tested and found to comply within the limits for a Class B digital device for radio noise for digital apparatus set out in the Radio Interference Regulations of the Canadian Department of Communication, and is pursuant to part 15 of the Federal Communication Commission (FCC) rules. These limits are designed to provide reasonable protection against harmful interference in a residential installation.

This receiver generates radio frequency. If it's not used in accordance with the instructions, it may cause harmful interference to radio or television reception. Such interference can be determined by turning the receiver off and on. You are encouraged to try eliminating the interference by one or more of the following measures:

- Reorient or relocate the receiving antenna.
- Increase the separation between the laser and the receiver.

For more information, consult your dealer or an experienced radio/television technician.

**CAUTION:** Changes or modifications to the receiver that are not expressly approved by Trimble could void authority to use the equipment.

### CE Declaration of Conformity

Application of Council Directive(s): 89/336/EEC  
 Manufacturer's Name: Trimble Navigation Ltd.  
 Manufacturer's Address: 5475 Kellenburger Road, Dayton, Ohio 45424-1099 U.S.A.  
 European Representative Address: Trimble GmbH Am Prime Parc 11, 65479 Raunheim, Germany  
 Model Number: HL760, HL760U  
 Conformance to Directive(s): EC Directive 89/336/EEC using EN55022, EN300-440, EN301-489 and EN61326  
 Equipment Type/Environment: ITE/residential, commercial & light industrial

### Notice to Our European Union Customers

For product recycling instructions and more information, please go to: [www.trimble.com/environment/summary.html](http://www.trimble.com/environment/summary.html)

#### Recycling in Europe

To recycle Trimble WEEE, call: +31 497 53 2430, and ask for the "WEEE associate," or



Mail a request for recycling instructions to:  
 Trimble Europe BV c/o Menlo Worldwide Logistics  
 Meerheide 45 5521 DZ Eersel, NL



Spectra Precision Division  
 5475 Kellenburger Road  
 Dayton, Ohio 45424-1099  
 U.S.A.  
 +1-937-245-5600 Phone

[www.trimble.com](http://www.trimble.com)

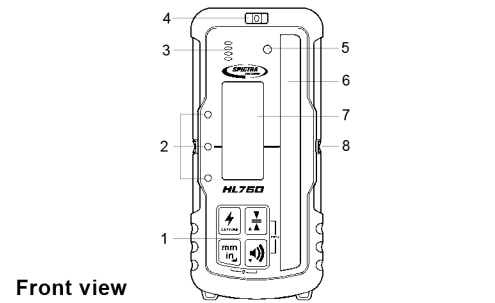
Front view

1. Keypad - Power, Accuracy, Units & Volume switches.
2. LED Display - Green for on-grade, Red for high, Blue for low
3. Beeper output - Fast, solid & slow audible signal.
4. Bubble Vial - aids in keeping level.
5. Anti-strobe sensor - Reduces false indication from strobe lights.
6. SuperCell Reception Window - 5.0 in / 127.0 mm of height.
7. Front LCD - Displays elevation, settings and status.
8. On-grade Mark - Aligned with laser center on-grade reading.

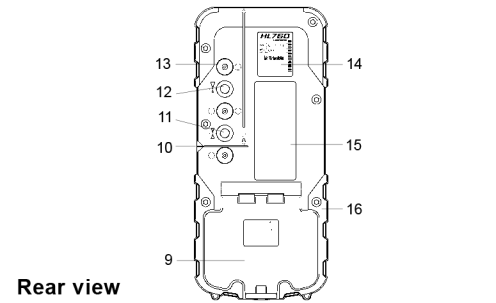

Rear view

9. Battery Door & Latch for two "AA" batteries.
10. Marking Notch (3.15 in / 80.0 mm from top).
11. Captive Screw Thread, Center on-grade clamp position.
12. Captive Screw Thread, Offset on-grade clamp position.
13. Clamp Guides - Dimples align rod clamp.
14. Serial Number / ID Label.
15. Rear LCD - repeats indications of front LCD.
16. Rubber over mold - Protects the unit from drops

## Installing the Batteries

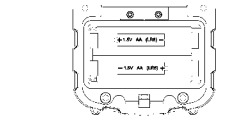

1. Open the battery door using a coin or similar pry device to release the battery door tab.
2. Insert two AA batteries noting the plus (+) and minus (-) diagrams inside the battery housing.
3. Close the battery door. Push down until it "clicks" into the locked position.

**Action**      **Display**      **Remarks**

**Turn power ON/OFF**

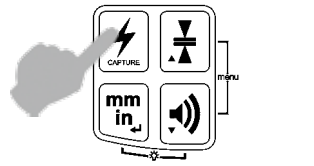
  
Press to turn power ON. Press and hold for 2 seconds to turn power OFF.

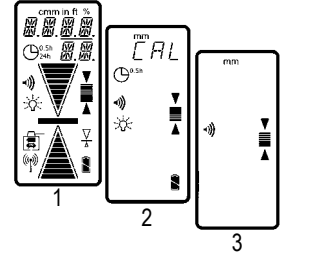

Initialization:  
1. Test of LCD, LED and beeper  
2. CAL: Calibration (3 sec.)  
3. Unit is ready for use.  
  
(Do not power up the unit in a laser beam or strobe. If detected, the unit will display "E200" and revert to the previous calibration.)

**Select accuracy**

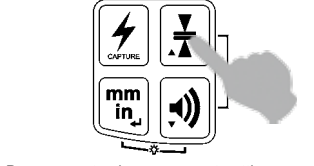
  
Press once to change current setting (A beep confirms the selected volume.)

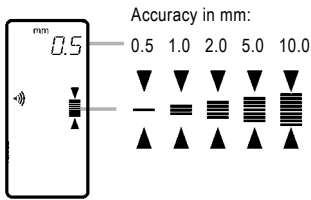

The selected unit of measure determines the displayed deadband (accuracy).  
  
The current accuracy is stored in memory and will be retained when the unit is turned off or when batteries are replaced.

**Select beeper volume**

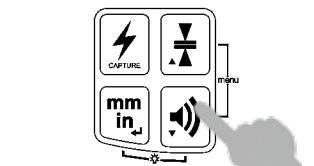
  
Press once to display current setting; push again to scroll through options.

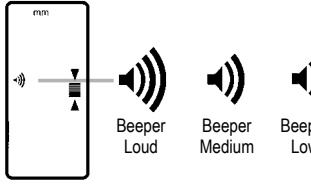

The current beeper volume is stored in memory and will be retained when the unit is turned off or when batteries are replaced.

**Select units of measure**

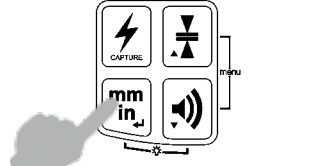
  
Press once to display current setting, additional pushes to scroll through options.

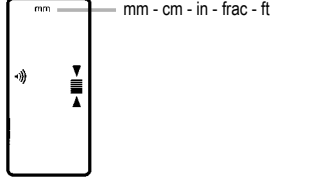

The current unit of measure is stored in memory and will be retained when the unit is turned off or when batteries are replaced.

**Select brightness of LEDs**

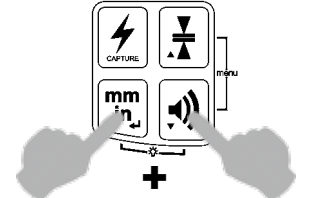
  
Press together to cycle the selection.

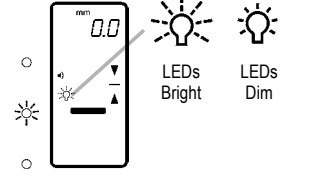

The current brightness of LEDs is stored in memory and will be retained when the unit is turned off or when batteries are replaced.

**Action**      **Display**      **Remarks**

**CAPTURE Function**

A) HL760 is **in the laser beam** and the power is on:

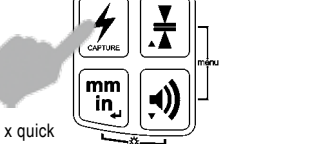

The current elevation reading will be held. A flashing display will confirm the reading has been captured.



Press any switch to return to normal operation.

B) HL760 is **out of the laser beam** and power is on:

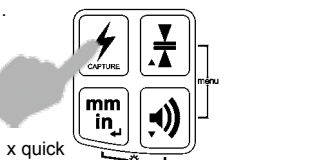

A short intermittent beep (The beeper will turn on to Low if turned off.)



The beeper will chirp rapidly after approximately 5 seconds to confirm beam capture. A flashing display will also indicate the reading has been captured.

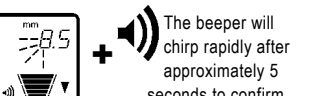

Press any switch to return to normal operation.

**Special Menu Functions**

Press switches together for 2 sec.

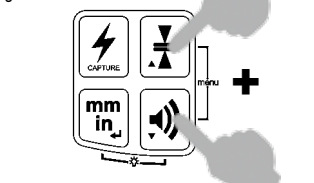

**MENU** (for 2 Sec., then RDIO)

- RDIO Radio Functions - MODE - PAIR - TEST
- SENS Sensitivity Medium\* - High - Low
- AVG Averaging algorithm Medium\* - High - Low
- D.R.O. Numeric display ON\* - OFF - 1mm
- UNIT Units of measure MM\* - CM - IN - FRAC - FT
- FRC.R. Fractional Reduction ON\* - OFF
- ARRW Arrow Display DB\* (deadband) - PR (prop.)
- O.O.B. Out-of-Beam Display ON\* - OFF
- GRD.A. Grade Alarm ON - OFF\*
- A.S.O. Automatic shutoff 0.5h\* - 24h - OFF
- TX.O.L. Transmitter Out-of-Level OFF\* - RPS
- TX.O.B. Transmitter Low Battery OFF\* - RPS
- INFO Information about the Laserometer

How to change Menu functions:

1. Scrolling up or down.
2. Enter Change mode.
3. Change selected items.
4. Confirm change.
5. To Exit.

**Out-of-Beam Display**  
**O.O.B. (Out-of-Beam Display):**  
Sequence to show direction to get back in the laser beam ( for 25 s)  
ON - Out-of-Beam Display ON\*  
OF - Out-of-Beam Display OFF

**Automatic Shutoff**  
**A.S.O. (Automatic Shut Off):**  
0.5 - After 30 Minutes\*  
OF - Off (Unit is permanently on.)  
24 - 24 hour shutoff.

**Special Menu Functions**

**RADIO Function**

- RDIO (Radio)** - Selects the 2-way radio operating conditions.
- ↳ **MODE** -
    - ↳ **OF** - Off, No radio operation
    - ↳ **LS** - Laser, radio is set to operate with a laser (see the laser user guide for using these features)
    - ↳ **HL** - Handheld Laserometer, the 2-way radio is set to operate with another HL760
  - ↳ **PAIR** - Configures the radio to work with a specific laser or HL760 Laserometer. (required only once for each device) Identification code of the paired device is stored in memory.
  - ↳ **TEST** - Displays the value of communication packets (Service Use Only)

**Remote Operation with Two HL760's**  
The HL760 can remotely display another HL760's elevation information up to 220 m (720 ft) away.



**1. Pair the Two HL760's**  
Turn on both HL760 Laserometers that are to be paired and follow below directions for both units. Enter the MENU of the HL760's. The RDIO functions will be shown. Enter the RDIO functions to display the MODE selection. If HL is not displayed, Enter the MODE function and scroll up or down to select HL for each HL760 and ENTER. Scroll down to PAIR function. ENTER to activate pairing. The PAIR symbol will rotate briefly until both units complete the PAIR operation. PAIR OK indicates function complete.

**2. Remote Operation**  
Turn both HL760's Off.  
The first HL760 turned on becomes the laser SENSOR (receiver). The second HL760 turned on becomes the REMOTE DISPLAY / CONTROL PANEL.  
Turn on the HL760 that is desired to be the SENSOR first. Mount at the desired elevation so that it can receive the laser beam.  
Turn on the HL760 that is desired to be the REMOTE DISPLAY / CONTROL PANEL second.  
RMT.D - OK will be displayed.  
Press ENTER to operate this HL760 as the REMOTE DISPLAY / CONTROL PANEL.

NOTE: If ENTER is not pressed, both HL760's will revert to standard operation.  
  
During REMOTE DISPLAY / CONTROL PANEL operation, RMT.D is displayed. The Unit will remotely display the elevation readings of the SENSOR, as long as the Antenna symbol shows the two are within radio range of each other up to 220 meters (720 ft).  
  
The RMT.D unit can remotely adjust the Accuracy and Units of Measure of the SENSOR.

**Special Menu Functions**      *Change special Menu Functions only in the case of special job requirements!*

**Sensitivity of reception**  
**SENS (Sensitivity):**  
Selects reception sensitivity to laser and other light sources.  
**MD** - Medium\*: for most applications.  
**HI** - High: When laser beam is weak, or at very long distances.  
**LO** - Low: If outside sources are disturbing elevation readings.

**VH** - Very High (HL760U only): for extremely long distances. VH should not be used indoors, as it can cause false signaling under fluorescent lights.  
  
*For more information about special Menu Function contact the manufacturer, importer or your local dealer.*

**Grade Alarm**  
**GRD.A. (Grade Alarm):**  
When turned ON, disables the audible signal when on-grade. When moved out of the on-grade deadband, the beeper activates as normal:  
ON - Alarm on (Solid beeper OFF)  
OF - Alarm off (Solid beeper ON)\*